



The Progress Group, Inc.
1390 North Hundley Street
Anaheim, California
92806

714.575.1193 PH
714.575.1198 FX
www.progressauto.com

INSTALLATION INSTRUCTIONS

CAUTION: Automotive coil springs store energy. Always use caution when removing coil springs. If you are not comfortable with the installation procedure, please consult a professional installer.

FIGURE 1.

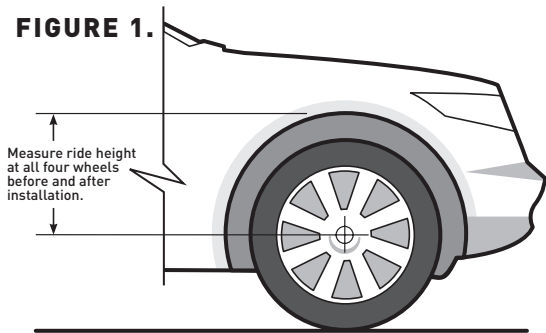

Before beginning installation, park the vehicle on a smooth, level asphalt or concrete surface. Measure the height of the vehicle from the center of the wheel to the bottom of the fender lip at all four corners, and record these measurements in the boxes below and on the product registration card. Also perform these measurements after installation. See illustration **Figure 1**.

[SAVE THESE SPECIFICATIONS]

LEFT FRONT	RIGHT FRONT	LEFT FRONT	RIGHT FRONT
LEFT REAR	RIGHT REAR	LEFT REAR	RIGHT REAR

[BEFORE] [AFTER]

- A** When disassembling your particular vehicle, please note where all factory spring insulators and bump stops are located. Inspect these parts for damage and replace any damaged components. These components must be used when installing your new PROGRESS coil springs to insure quiet operation and proper ride height.
- B** Because of design considerations, your PROGRESS sport springs may look different from your original equipment (stock) springs. This is normal, and your new springs should fit your vehicle properly regardless of these differences.
- C** When installing your springs, make sure that the top and bottom of the coil springs are properly located in their mounts, and that all factory rubber insulators are installed.
- D** On strut equipped vehicles, any bump stops (compression stops) that are located on the strut piston rod (the chrome shaft coming out of the top of the strut or cartridge) should be trimmed in half to improve wheel travel and ride quality. On some vehicles, the bumpstops may be located on the axle, frame or suspension control arms. These should be located and the height trimmed in half. See **Figure 2**.
- E** Bumpstops must be installed on all vehicles to avoid damaging suspension components. DO NOT remove bumpstops to gain additional wheel travel.
- F** After installation, a proper wheel alignment **MUST BE PERFORMED** to provide safe handling and maximum tire life. On some vehicles, use of aftermarket components may be required to allow proper alignment.

FIGURE 2.

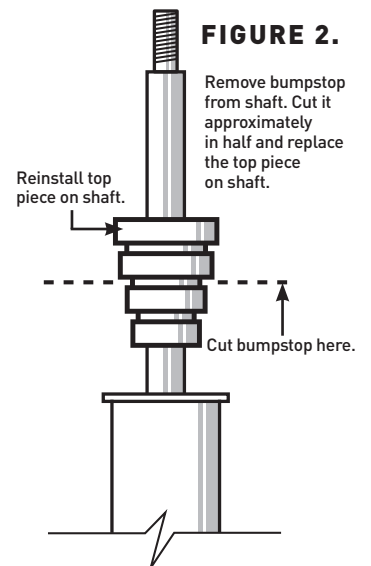

[PLEASE DETACH AND MAIL]



PRODUCT REGISTRATION CARD

Please read your instructions before installation.

Satisfaction Index (circle one) **A** **B** **C** **D** **F**

Name _____

Address _____

City _____ State _____ ZIP _____

E-mail _____

Vehicle _____

Model _____

Year _____

Please fill in vehicle ride heights before and after installation.

LEFT FRONT	RIGHT FRONT	LEFT FRONT	RIGHT FRONT
LEFT REAR	RIGHT REAR	LEFT REAR	RIGHT REAR

[BEFORE] [AFTER]

Part No(s) purchased _____

Purchased from _____



THE PROGRESS GROUP, INC. WARRANTY

The Progress Group, Inc. warrants to the original retail purchaser, who retains ownership of the vehicle on which the product was originally installed, all of its Progress Sport Springs for life. Competition-Series Coil-overs, Alignment kits and Anti-roll bars are warranted for one year from date of purchase. This warranty only protects the original purchaser from defects in material and workmanship when used on passenger cars under normal use. An invoice is required for any warranty claim.

Excluded from the warranty are the cosmetic finish and/or plating of the product, and any product which has been altered, modified, misused, subjected to accident or collision, improperly installed, or installed on a vehicle for which it is not originally designed or intended.

The Progress Group, Inc.'s obligation under this warranty is limited to the repair or replacement, at The Progress Group's option, of the defective product. Any costs for freight, removal, installation, re-installation, loss of time or revenues, inconvenience, loss of use of vehicle and any other type of incidental, indirect, or consequential damages are expressly excluded from this warranty.

The Progress Group, Inc. reserves the right to make changes in design, materials, and specifications as deemed necessary without prior notice. Obligations or liabilities will not be assumed to modify or exchange any product previously manufactured. The Progress Group, Inc. makes no warranty as to the compatibility of its coil spring products with other aftermarket components, such as wheels, tires, and/or other suspension components.

This warranty sets forth The Progress Group, Inc.'s entire warranty and may not be modified or supplanted by any other person or company whether in writing or in oral statements. There are no warranties, expressed or implied (including any implied warranties merchantability and fitness for a particular purpose), which extend beyond the description on the face hereof. Any implied warranties are disclaimed to the fullest extent permitted by law and in no event are to exceed the purchase price of the product. This warranty supercedes any earlier warranty policies. Some states do not allow limitations on how long an implied warranty lasts, and/or do not allow limitation of incidental or consequential damages, so the above limitations or exclusions may not apply to you. This warranty gives you specific legal rights, and you may have other rights, which vary from state to state.

Also available from your Progress Technology Dealer.



SPORT SPRING KITS



ANTI-ROLL BAR SYSTEMS



COMPETITION SERIES COIL OVERS



ALIGNMENT KITS

Visit our website for more information www.progressauto.com

[PLEASE DETACH AND MAIL]

Comments



THANK YOU FOR CHOOSING PROGRESS TECHNOLOGY!

Please return with the envelope provided.